

 <p>12 , 43</p>	 <p>125</p>	 <p>126</p>
 <p>127</p>	 <p>143</p>	 <p>144</p>
 <p>151</p>	 <p>153</p>	 <p>154</p>
 <p>157</p> <p>158</p> <p>159</p>		

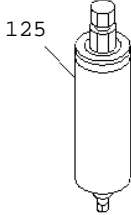
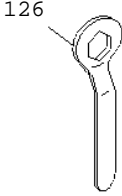
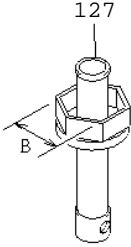
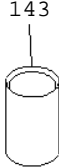
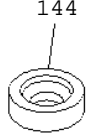
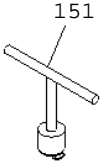

9-01

TOOLS

KEY	R / C	PART NAME PART NUMBER	I T C	APPLIED DATE	Qty	APPLIED MODEL	RESTRICTION/REMARKS
							A FVR WIDE CAB(FGR5MV) B GVR WIDE CAB(GGR5MV)
1		HANDLE; SPARE TIRE CARRIER 9-23110-018-0		1312-1402	01	A	SPARE WHEEL CARRIER FRAME REAR(P10) IDN
		9-23110-018-0		1403-	01	A	SPARE WHEEL CARRIER FRAME REAR(P10) IDN
		9-23110-018-0		1403-	01	B	SPARE TIRE CARRIER LIFTING TYPE VAR1(SY8) IDN
9		WRENCH; WHEEL PIN 1-85113-015-1		1312-1402	01	A	B=41X21 L=440 IDN
		1-85113-015-1		1403-	01	AB	B=41X21 L=440 IDN
12		HANDLE; WRENCH,WHEEL PIN 1-85116-011-0		1312-1402	01	A	OD=25 L=480 IDN
		1-85116-011-0		1403-	01	AB	OD=25 L=480 IDN
13		WRENCH; MONKEY 1-85117-006-0		1312-1402	01	A	L=247 IDN
		1-85117-006-0		1403-	01	AB	L=247 IDN
17		HAMMER 9-85121-406-0		1312-1402	01	A	IDN
		9-85121-406-0		1403-	01	AB	IDN
20		WRENCH; 10X12 0-95902-510-0		1312-1402	01	A	10X12 IDN
		0-95902-510-0		1403-	01	AB	10X12 IDN
21		WRENCH; 14X17 0-95902-514-0		1312-1402	01	A	14X17 IDN
		0-95902-514-0		1403-	01	AB	14X17 IDN
22		WRENCH; 19X22					

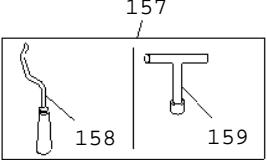
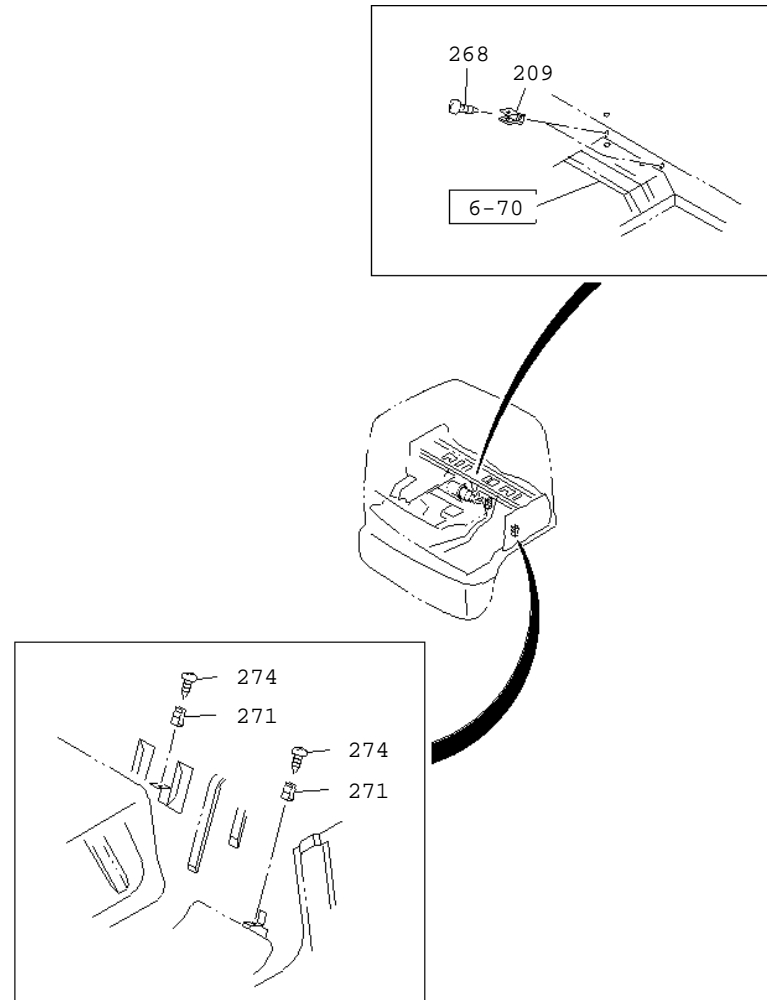
9-01

TOOLS

KEY	R / C	PART NAME PART NUMBER	I T C	APPLIED DATE	Qty	APPLIED MODEL	RESTRICTION/REMARKS
							A FVR WIDE CAB (FGR5MV) B GVR WIDE CAB (GGR5MV)
22		0-95902-519-0		1312-1402	01	A	19X22 IDN
		0-95902-519-0		1403-	01	AB	19X22 IDN
23		WRENCH; 24X27 0-95902-524-0		1312-1402	01	A	24X27 IDN
		0-95902-524-0		1403-	01	AB	24X27 IDN
29		DRIVER; SCREW 8-94242-798-1		1312-1402	01	A	(C) <+>, <-> L=160 IDN
		8-94242-798-1		1403-	01	AB	(C) <+>, <-> L=160 IDN
		8-98061-105-0		1312-1402	01	A	(B) <-> L=275 IDN
		8-98061-105-0		1403-	01	AB	(B) <-> L=275 IDN
		9-09595-522-0		1312-1402	01	A	(A) <+> L=190 IDN
		9-09595-522-0		1403-	01	AB	(A) <+> L=190 IDN
43		BAR; EXTENSION, SOCKET WRENCH 1-85116-011-0		1312-1402	01	A	OD=25 L=480 IDN
		1-85116-011-0		1403-	01	AB	OD=25 L=480 IDN
115		PLIER 5-85171-002-0		1312-1402	01	A	IDN

9-01

TOOLS

KEY	R / C	PART NAME PART NUMBER	I T C	APPLIED DATE	Qty	APPLIED MODEL	RESTRICTION/REMARKS
							A FVR WIDE CAB (FGR5MV) B GVR WIDE CAB (GGR5MV)
115		5-85171-002-0		1403-	01	AB	
125		PULLER ASM; KING PIN 1-85210-009-0		1312-1402	01	A	IDN
		1-85210-009-0		1403-	01	AB	L=450
126		WRENCH; FRT HUB BRG NUT 1-85110-002-1		1312-1402	01	A	L=450
		1-85110-002-1		1403-	01	AB	L=350 B=75
127		WRENCH ASM; HUB BRG NUT 8-98119-000-1		1312-	01	A	L=350 B=75
129		PULLER ASM; PITMAN ARM 1-85210-011-0		1312-1402	01	A	L=400 B=116
		1-85210-011-0		1403-	01	AB	
143		GUIDE; BOOT,TIE ROD END 1-85229-013-0		1312-1402	01	A	
		1-85229-013-0		1403-	01	AB	
144		BASE; BOOT GUIDE,TIE ROD END 1-85229-009-0		1312-1402	01	A	
		1-85229-009-0		1403-	01	AB	
151		REMOVER; OIL BRK,FRT RETURN SPR 1-85237-002-0		1312-1402	01	A	ID=16
		1-85237-002-0		1403-	01	AB	ID=16
153		DRIVER; WASHER,THRUST WASHER 1-85238-002-0		1312-1402	01	A	
		1-85238-002-0		1403-	01	AB	
154		SLEEPER; KING PIN 1-85238-003-0		1312-1402	01	A	
		1-85238-003-0		1403-	01	AB	
157		REPLACER KIT; RETURN SPR 9-85231-554-0		1312-1402	01	A	
		9-85231-554-0		1403-	01	AB	
158		SETTING TOOL; RETURN SPR 9-85221-231-0		1312-1402	01	A	
		9-85221-231-0		1403-	01	AB	
159		REMOVER; RETURN SPR 9-85231-555-0		1312-1402	01	A	ID=12.5
		9-85231-555-0		1403-	01	AB	ID=12.5
160		REMOVER; NEEDLE BRG					

9-01

TOOLS

KEY	R / C	PART NAME PART NUMBER	I T C	APPLIED DATE	Qty	APPLIED MODEL	RESTRICTION/REMARKS
							A FVR WIDE CAB (FGR5MV) B GVR WIDE CAB (GGR5MV)
160		1-85238-001-0		1312-1402	01	A	
		1-85238-001-0		1403-	01	AB	L=220
162		SETTING TOOL; NEEDLE BRG 1-85238-008-0		1312-1402	01	A	L=220
		1-85238-008-0		1403-	01	AB	(A) L=181
		1-85238-009-0		1312-1402	01	A	(A) L=181
		1-85238-009-0		1403-	01	AB	(B) L=213
164		GUIDE; SNAP RING PILOT BRG 1-85176-001-0		1312-1402	01	A	(B) L=213
		1-85176-001-0		1403-	01	AB	
174		PULLER ASM; MAIN CLU SHAFT 9-85210-148-0		1403-1405	01	B	
		9-85210-148-0		1406-	01	A	ZF9S1110 DD M/T(Y5P)
		9-85210-148-0		1406-	01	B	
192		GAUGE; TIRE PRESSURE 1-85315-002-0		1312-1402	01	A	
		1-85315-002-0		1403-	01	AB	
193		JACK ASM 1-85510-019-2		1312-1402	01	A	15TON
		1-85510-019-2		1403-	01	AB	15TON
208		HANDLE; JACK 8-98181-437-0		1312-1402	01	A	L=600 IDN
		8-98181-437-0		1403-	01	AB	L=600 IDN
209		CLIP; JACK HANDLE 8-98053-799-0		1312-1402	02	A	
		8-98053-799-0		1403-	02	AB	
227		PUMP ASM; TIRE 9-85521-132-0		1312-1402	01	A	
		9-85521-132-0		1403-	01	AB	
230		PUMP; GREASE 1-85556-007-5		1312-1402	01	A	IDN

9-01

TOOLS

KEY	R / C	PART NAME PART NUMBER	I T C	APPLIED DATE	Qty	APPLIED MODEL	RESTRICTION/REMARKS
							A FVR WIDE CAB (FGR5MV) B GVR WIDE CAB (GGR5MV)
230		1-85556-007-5		1403-	01	AB	IDN
237		BAG; TOOL 8-97130-902-1		1312-1402	01	A	IDN
		8-97130-902-1		1403-	01	AB	IDN
268		SCREW; CLIP 0-38050-612-0		1312-1402	02	A	M6X12 HEXALOBULAR SOCKET
		0-38050-612-0		1403-	02	AB	M6X12 HEXALOBULAR SOCKET
271		CLIP; TIRE HANGER 8-98053-800-0		1312-1402	02	A	
		8-98053-800-0		1403-	02	AB	
274		SCREW; CLIP 0-38050-612-0		1312-1402	02	A	M6X12 HEXALOBULAR SOCKET
		0-38050-612-0		1403-	02	AB	M6X12 HEXALOBULAR SOCKET
6-70		Move to 6-70					