

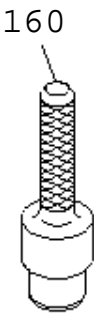

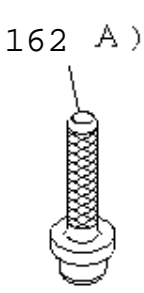

 <p>129</p>	 <p>160</p>	 <p>162 A)</p>
 <p>162 B)</p>	 <p>164</p>	 <p>174</p>
 <p>192</p>	 <p>227</p>	

 <p>12 , 43</p> <p>OD</p> <p>L</p>	 <p>125</p>	 <p>126</p>
 <p>127</p> <p>B</p>	 <p>143</p>	 <p>144</p>
 <p>151</p>	 <p>153</p>	 <p>154</p> <p>B</p>
 <p>157</p> <p>158</p> <p>159</p>		

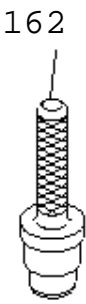

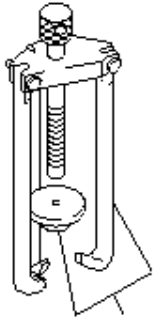
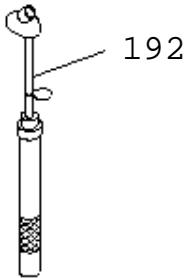
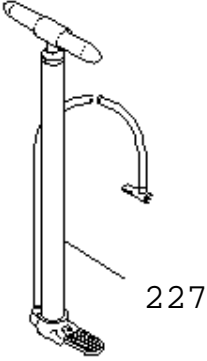
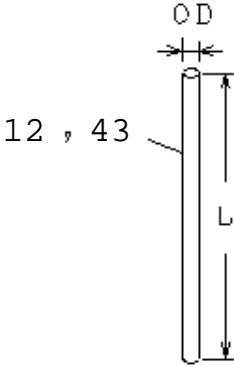
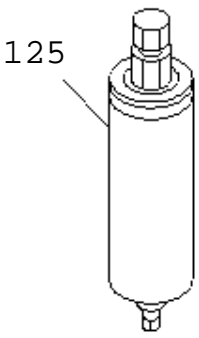
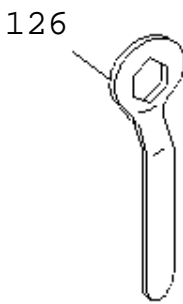
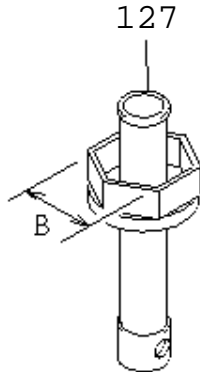
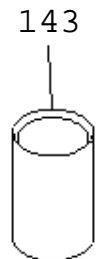
9-01

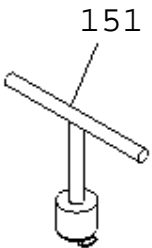
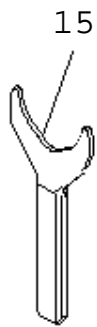
TOOLS

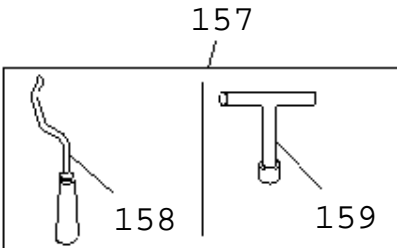
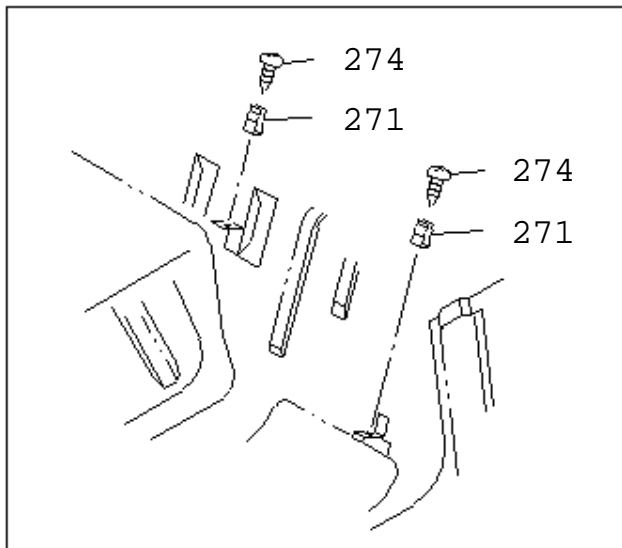
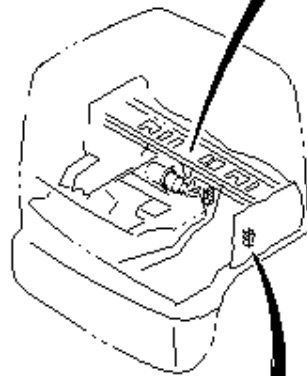
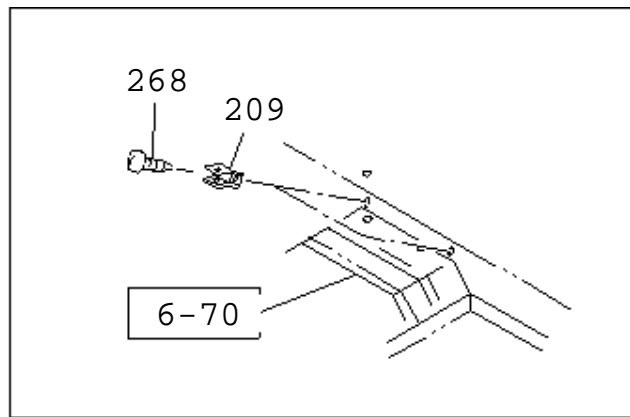
KEY	R / C	PART NAME PART NUMBER	I T C	APPLIED DATE	Qt-y	APPLIED MODEL	RESTRICTION/REMARKS
							A FVZ WIDE CAB(FGZ5MV) B GVZ WIDE CAB(GGZ5MV)
1		HANDLE; SPARE TIRE CARRIER 9-23110-018-0		1312-1403	01	A	SPARE WHEEL CARRIER FRAME REAR(P10) IDN
		9-23110-018-0		1404-	01	A	SPARE WHEEL CARRIER FRAME REAR(P10) IDN
		9-23110-018-0		1404-	01	B	SPARE TIRE CARRIER LIFTING TYPE VAR1 IDN
9		WRENCH; WHEEL PIN 1-85113-015-1		1312-1403	01	A	B=41X21 L=440 IDN
		1-85113-015-1		1404-	01	AB	B=41X21 L=440 IDN
12		HANDLE; WRENCH,WHEEL PIN 1-85116-011-0		1312-1403	01	A	OD=25 L=480 IDN
		1-85116-011-0	A	1404-1409	01	AB	OD=25 L=480 IDN
		8-98257-407-0		1410-	01	AB	OD=25 L=480 IDN
13		WRENCH; MONKEY 1-85117-006-0		1312-1403	01	A	L=247 IDN
		1-85117-006-0		1404-1407	01	AB	L=247 IDN
		8-98270-303-0		1408-	01	AB	L=255 IDN
17		HAMMER 9-85121-406-0		1312-1403	01	A	IDN
		9-85121-406-0		1404-	01	AB	IDN
20		WRENCH; 10X12 0-95902-510-0		1312-1403	01	A	10X12 IDN
		0-95902-510-0		1404-	01	AB	10X12 IDN
21		WRENCH; 14X17 0-95902-514-0		1312-1403	01	A	14X17 IDN
		0-95902-514-0		1404-	01	AB	14X17 IDN
22		WRENCH; 19X22 0-95902-519-0		1312-1403	01	A	19X22 IDN
		0-95902-519-0		1404-	01	AB	19X22 IDN
23		WRENCH; 24X27 0-95902-524-0		1312-1403	01	A	24X27 IDN
		0-95902-524-0		1404-	01	AB	24X27 IDN
29		DRIVER; SCREW 8-94242-798-1		1312-1403	01	A	(C) <+>, <-> L=160 IDN

9-01

TOOLS

KEY	R / C	PART NAME PART NUMBER	I T C	APPLIED DATE	Qt-y	APPLIED MODEL	RESTRICTION/REMARKS
							A FVZ WIDE CAB(FGZ5MV) B GVZ WIDE CAB(GGZ5MV)
29		8-94242-798-1		1404-	01	AB	(C) <+>, <-> L=160 IDN
		8-98061-105-0		1312-1403	01	A	(B) <-> L=275 IDN
		8-98061-105-0		1404-	01	AB	(B) <-> L=275 IDN
		9-09595-522-0		1312-1403	01	A	(A) <+> L=190 IDN
		9-09595-522-0		1404-	01	AB	(A) <+> L=190 IDN
43		BAR; EXTENSION, SOCKET WRENCH 1-85116-011-0		1312-1403	01	A	OD=25 L=480 IDN
		1-85116-011-0	A	1404-1409	01	AB	OD=25 L=480 IDN
		8-98257-407-0		1410-	01	AB	OD=25 L=480 IDN
115		PLIER 5-85171-002-0		1312-1403	01	A	IDN
		5-85171-002-0		1404-	01	AB	IDN
125		PULLER ASM; KING PIN 1-85210-009-0		1312-1403	01	A	L=450
		1-85210-009-0		1404-	01	AB	L=450
126		WRENCH; FRT HUB BRG NUT 1-85110-002-1		1312-1403	01	A	L=350 B=75
		1-85110-002-1		1404-	01	AB	L=350 B=75
127		WRENCH ASM; HUB BRG NUT 8-98119-000-1		1312-	01	A	L=400 B=116
129		PULLER ASM; PITMAN ARM 1-85210-011-0		1312-1403	01	A	
		1-85210-011-0		1404-	01	AB	
143		GUIDE; BOOT, TIE ROD END 1-85229-013-0		1312-1403	01	A	
		1-85229-013-0		1404-	01	AB	
144		BASE; BOOT GUIDE, TIE ROD END 1-85229-009-0		1312-1403	01	A	
		1-85229-009-0		1404-	01	AB	
151		REMOVER; OIL BRK, FRT RETURN SPR 1-85237-002-0		1312-1403	01	A	ID=16
		1-85237-002-0		1404-	01	AB	ID=16
153		DRIVER; WASHER, THRUST WASHER 1-85238-002-0		1312-1403	01	A	
		1-85238-002-0		1404-	01	AB	
154		SLEEPER; KING PIN 1-85238-003-0		1312-1403	01	A	
		1-85238-003-0		1404-	01	AB	
157		REPLACER KIT; RETURN SPR 9-85231-554-0		1312-1403	01	A	
		9-85231-554-0		1404-	01	AB	
158		SETTING TOOL; RETURN SPR 9-85221-231-0		1312-1403	01	A	
		9-85221-231-0		1404-	01	AB	

9-01

TOOLS

KEY	R / C	PART NAME PART NUMBER	I T C	APPLIED DATE	Qt-y	APPLIED MODEL	RESTRICTION/REMARKS	
							A FVZ WIDE CAB (FGZ5MV)	B GVZ WIDE CAB (GGZ5MV)
159		REMOVER; RETURN SPR 9-85231-555-0		1312-1403	01	A		
		9-85231-555-0		1404-	01	AB	ID=12.5	
160		REMOVER; NEEDLE BRG 1-85238-001-0		1312-1403	01	A		
		1-85238-001-0		1404-	01	AB	L=220	
162		SETTING TOOL; NEEDLE BRG 1-85238-008-0		1312-1403	01	A		
		1-85238-008-0		1404-	01	AB	L=220	
		1-85238-009-0		1312-1403	01	A	(A) L=181	
		1-85238-009-0		1404-	01	AB	(A) L=181	
164		GUIDE; SNAP RING PILOT BRG 1-85176-001-0		1312-1403	01	A		
		1-85176-001-0		1404-	01	AB		
174		PULLER ASM; MAIN CLU SHAFT 9-85210-148-0		1312-1403	01	A		
		9-85210-148-0		1404-	01	AB		
192		GAUGE; TIRE PRESSURE 1-85315-002-0		1312-1403	01	A		
		1-85315-002-0		1404-	01	AB		
193		JACK ASM 1-85510-019-2		1312-1403	01	A		
		1-85510-019-2		1404-	01	AB	15TON	
208		HANDLE; JACK 8-98181-437-0		1312-1403	01	A		
		8-98181-437-0		1404-	01	AB	15TON	
209		CLIP; JACK HANDLE 8-98053-799-0		1312-1403	02	A		
		8-98053-799-0		1404-	02	AB	L=600 IDN	
227		PUMP ASM; TIRE 9-85521-132-0		1312-1403	01	A		
		9-85521-132-0		1404-	01	AB		
230		PUMP; GREASE 1-85556-007-5		1312-1403	01	A		
		1-85556-007-5		1404-	01	AB	IDN	
237		BAG; TOOL 8-97130-902-1		1312-1403	01	A		
		8-97130-902-1		1404-	01	AB	IDN	
268		SCREW; CLIP 0-38050-612-0		1312-1403	02	A		
		0-38050-612-0		1404-	02	AB	M6X12 HEXALOBULAR SOCKET	
271		CLIP; TIRE HANGER 8-98053-800-0		1312-1403	02	A		
		8-98053-800-0		1404-	02	AB	M6X12 HEXALOBULAR SOCKET	
274		SCREW; CLIP 0-38050-612-0		1312-1403	02	A		
		0-38050-612-0		1404-	02	AB	M6X12 HEXALOBULAR SOCKET	
6-70		Move to 6-70						